

627



Medical IT System Insulation Monitoring and Fault Locating
Devices
(Six-Piece Set)

Installation and Operation Manual V1.0

Acrel Co., Ltd.

Declaration

Please read this manual carefully before using these series of products. In this manual, all pictures, logos, symbols, etc. are all reserved by the Acrel Electric Co., Ltd. Personnel not inside the company shall not publicly reprint all or part of the contents without written authorization.

Before using the IT system which is made up of this series of products, please read the tips and precautions in this operation manual, and Acrel does not take responsibility for personal injuries or economic losses caused by ignoring tips of this manual;

Transformers and related insulation monitors are professional electrical equipment, and any relevant operation needs to be carried out by specialized electrical technicians. Acrel does not take responsibility for personal injuries or economic losses caused by improper operations of non-professionals.

The contents of the manual will be continuously updated and revised, thus the products functions in this manual may inevitably have a slight discrepancy with the real objects during the continuous upgrading process. Users should give first place to the purchased real products, and can search *www. acrel. cn* to downloads or through sales channels to obtain the latest version of the manual.

Table of Contents

1	Introduction.....	1
2	Function features.....	3
2.1	Function features of AITR series medical isolation transformer.....	3
2.2	Function features of AIM-M300 series medical intelligent monitoring device	3
2.3	AIL150-4/AIL150-8/AIL160-6 insulation fault locator.....	3
2.5	Function features of AID150 centralized alarm and display device.....	3
2.6	Function features of HDR-60-24 power supply device.....	4
2.7	Function features of AKH-0.66P26 current transformer.....	4
3	Reference standard.....	4
4	Technical parameters.....	5
4.1	Technical parameters of AITR series medical isolation transformer.....	5
4.2	Technical parameters of AIM-M300 series medical intelligent insulation monitoring device.....	6
4.3	Technical parameters of AIL150-4/AIL150-8 /AIL160-4test signal generator...7	
4.4	Technical parameters of AID150 centralized alarm and display device.....	7
4.5	Technical parameters of HDR-60-24 power supply device.....	8
4.6	Technical parameters of AKH-0.66P26 current transformer.....	8
5	Installation and wiring.....	8
5.1	Shape and cut-out.....	8
5.2	Installation.....	11
5.3	Wiring method.....	13
5.4.1	Typical wiring diagram.....	16
5.5	Note.....	18
6	Programming and application.....	19
6.1	Panel description.....	19

6.2 LED indicator instructions.....	20
6.3 Button function descriptions.....	21
6.4 Button operation descriptions.....	22
7 Communication protocol.....	27
7.1 Modbus-RTU communication protocol.....	27
7.2 CAN communication description.....	31
8 Typical applications.....	34
8.1 Applications of insulation monitoring and fault locating six pieces of products in ICU/CCU.....	34
9 Powerup and debugging instructions.....	35
9.1 Wiring check.....	35
9.2 Common faults and eliminations.....	36
9.3 Settings and debugging.....	37



Medical IT System Insulation Monitoring and Fault Locating Devices





1 Introduction

The medical IT system is mainly used in important Class 2 medical locations such as operating room, ICU/CCU intensive care unit, providing safe, reliable and continuous power distribution for the important equipment at these locations. Medical insulation monitoring and fault locating device is developed by Acrel with many years' design experience, according to the special requirements of the insulation monitoring and fault locating of the power distribution system in Class 2 medical locations. The products can realize the real-time monitoring of insulation, load and temperature of isolation transformer in IT system, and have the functions of system insulation fault locating and centralized monitoring by multiple pieces of systems.

Medical IT system insulation monitoring and fault locating products (Six-piece set) include AITR series medical isolation transformer, AIM-M300(or AIM-M300/SG) medical intelligent insulation monitoring device, AKH-0.66P26 current transformer, AIL150-4/AIL150-8 /AIL160-6 insulation fault locator, HDR-60-24 power module and AID150 centralized alarm and display device, which are shown in Table 1.

Table 1 Medical IT System Insulation Monitoring and Fault Locating Products

Name and type	Product picture	Description
AITR series medical isolation transformer		<p>AITR series isolation transformer is specially used in medical IT system. The windings are treated with double insulation and have electrostatic shielding layer, which reduces electromagnetic interference between windings. The PT100 temperature sensor is installed in the wire bag to monitor the temperature of transformer. The whole body is treated with vacuum invasion paint, which increases mechanical strength and corrosion resistance.</p>
AIM-M300 series medical intelligent insulation monitor		<p>AIM-M300 series medical intelligent monitoring device adopts advanced microcontroller technology, which has high integration, compact size, convenient installation and integrates intelligence, digitalization and networking in one. It is suitable for insulation monitoring of isolation power system in Class 2 medical locations</p>

		such as operating room and intensive care unit.
AKH-0.66P26 current transformer		The AKH-0.66P26 type current transformer is the protective current transformer supporting the AIM-M300 series insulation monitor, of which the maximum measurable current is 60A and the transformation ratio is 2000:1. The current transformer is directly fixed inside cabinet by screwing, and the secondary side is leaded out by the terminal, which is convenient to install and use.
AIL150-4/AIL150-8 /AIL160-6 insulation fault locator		AIL150-4/AIL150-8 /AIL160-6 insulation fault locator adopts high sensitivity transformer combined with high precision signal detecting circuit, which detects the signal inject in the system from AIM-M300/SG and accurately locates the circuits which have insulation faults. AIL150-4 insulation fault locator can locate the insulation faults of 4 loops, AIL150-8 insulation fault locator can locate 8 loops, and AIL160-6 locate 6 loops.
HDR-60-24 power module		HDR-60-24 DC power supply can provide 24V DC power supply simultaneously for AIM-M300 series medical intelligent insulation monitoring device, AIL150 and AIL160 series insulation fault locator and AID150 centralized alarm and display device. With high capacity, stable voltage output and convenient installation, the module meets the power-supply requirements of the above-mentioned meters and is the recommended power supply product.
AID150 centralized alarm and display device		AID150 centralized alarm and display device adopts the LCD liquid crystal display and achieves data exchange with AIM-M300 series medical intelligent insulation monitoring device through RS485 communication interface, which can real-time

		monitor multi-channel data of AIM-M300 series medical intelligent insulation monitoring device.
--	--	---

2 Function features

2.1 Function features of AITR series medical isolation transformer

- The transformation ratio between the primary and secondary windings is 1:1.
- Double insulation treatment is adopted between the windings, and the electrostatic shielding layer is designed.
- The PT100 temperature sensor is installed in each wire packet to monitor the temperature of the isolation transformer.
- Used for the transformation of TN system into IT system (ungrounded system) after isolation transformer.

2.2 Function features of AIM-M300 series medical intelligent monitoring device

- Functions of real-time monitoring and fault alarming of the grounding insulation resistance, transformer load current and transformer winding temperature of the monitored IT system;
- Locating current injector for insulation fault location systems;
- Real-time monitor the line disconnection fault, current sensor disconnection fault and the functional grounding line disconnection fault of the monitored system, and give the alarm indication within 2s after the fault occurs. when the fault occurs;
- Relay alarm output, LED alarm indication and other faults indication functions;
- Two kinds of fieldbus communication technology, which are used for centralized alarm and display device, insulation fault locator and upper computer management software communications, and monitoring the operation status of IT system in real time.
- Events logging function, which can record alarm occurrence time and fault type and is convenient for operation personnel to analyze the operation conditions of system and promptly eliminate the faults.

2.3 AIL150-4/AIL150-8/AIL160-6 insulation fault locator

- The CAN bus technology is used to exchange data with other equipment.
- Cooperate with AIM-M300/SG to realize fault locating function, in which the AIL150-4 locates 4 channels , AIL150-8 locates 8 channels. And AIL160-6 locates 6 channels in all.

2.5 Function features of AID150 centralized alarm and display device

- Remotely monitor the real-time operation conditions of up to 16 pieces of systems, and the main interface displays whether the communication is connect or not;

- Remotely setting the insulation resistance alarm value, load current alarm value and transformer temperature alarm value of each system insulation monitoring device, and remotely activated self-test of the insulation monitor.
- When insulation faults, overload, excessive temperature rise of the transformer or wiring faults occurred in any of the monitored system, centralized alarm and display device will provide corresponding audible and visual alarm signals, and can manually mute the alarm sound.
- Events logging function, which is convenient for operation personnel to analyze the operation conditions of system and promptly eliminate the faults, and can save maximum of 20 latest records;

2.6 Function features of HDR-60-24 power supply device

- AC 220V input, DC 24V output, with max output power of 60W;
- Used for the DC 24V power supply for AIM-M300 series medical intelligent insulation monitoring device, AIL150/AIL160 series insulation fault locator, AID150 centralized alarm and display device and other devices.

2.7 Function features of AKH-0.66P26 current transformer

- The maximum measurable current is 60A, and the transformation change ratio is 2000:1;
- Work with the AIM-M300 series insulation monitoring device to measure the load current of isolation transformer.

3 Reference standard

- ◆ IEC 60364-7-710: 2002 *Building electrical installations section 7-710: Requirements for special installations or locations---medical locations*;
- ◆ IEC 61557-8-2014 *Electrical safety of low voltage distribution system below AC 1000V and DC 1500V, Test, measurement or monitoring equipment for protection test section 8: Insulation monitoring device for IT systems*;
- ◆ IEC 61557-9-2014 *Electrical safety of low voltage distribution system below AC 1000V and DC 1500V, Test, measurement or monitoring equipment for protection test section 9: insulation fault positioning equipment for IT systems*;
- ◆ IEC61558-1: 2009 *Safety of power transformers, power supplies, reactors and similar products section 1: General requirements and tests*;
- ◆ IEC61558-2-15: 2011 *Safety of power transformers, power supplies and similar products section*

16: Special requirements for isolation transformers for power supply in medical locations.

4 Technical parameters

4.1 Technical parameters of AITR series medical isolation transformer

Refer to Table 2.

Table 2 Technical Parameters of AITR Series of Medical Isolation Transformer

Type	AITR10000S	AITR8000S	AITR6300S	AITR5000S	AITR3150S
Insulation class	H	H	H	H	H
Protection class	IP00	IP00	IP00	IP00	IP00
Power /Voltage /Current					
Rated power	10000VA	8000VA	6300VA	5000VA	3150VA
Rated frequency	50-60Hz	50-60Hz	50-60Hz	50-60Hz	50-60Hz
Rated input voltage	AC230V	AC230V	AC230V	AC230V	AC230V
Rated input current	45.3A	36A	28.5A	22.5	14.2A
Rated output voltage	AC230V/115V	AC230V/115V	AC230V/115V	AC230V/115V	AC230V/115V
Rated output current	43.5A	34.7A	27.4A	21.7	13.7A
Inrush current	<12In	<12In	<12In	<12In	<12In
Leakage current	<200 μ A	<200 μ A	<200 μ A	<200 μ A	<200 μ A
No load input current	1.359A	1.08A	0.855A	0.675A	0.426A
No load output voltage	235V ± 3%	235V ± 3%	235V ± 3%	235V ± 3%	235V ± 3%
Short circuit voltage	<6.9V	<6.9V	<6.9V	<6.9V	<7.5V
General parameters					
Fuse wire	80A	63A	50A	35A	25A
Primary winding resistance	<55mΩ	<64mΩ	<80mΩ	<131 mΩ	<245mΩ
Secondary winding resistance	<45mΩ	<64mΩ	<80mΩ	<116 mΩ	<228mΩ
Iron loss	<150W	<105W	<107W	<77W	<55W
Copper loss	<230W	<200W	<170W	<125W	<120W
Efficiency	>96%	>96%	>96%	>96%	>95%
Maximum ambient temperature	<40℃	<40℃	<40℃	<40℃	<40℃
No-load temperature rise	<36℃	<33℃	<31℃	<26℃	<22℃
Full load temperature rise	<65℃	<76℃	<67℃	<62℃	<55℃
Noise grade	<40dB	<40dB	<40dB	<40dB	<40dB

4.2 Technical parameters of AIM-M300 series medical intelligent insulation monitoring device

Refer to Table 3.

Table 3 Technical Parameters of AIM-M300 series Medical Intelligent Insulation Monitoring

AUX Power	Voltage	DC 18...36V	Temperature monitoring	Thermal resistor	2 Pt100
	Power consumption	$\leq 6W$		Measuring range	-50...+200°C
Insulation monitoring	Resistance measuring range	15...999k Ω		Alarm value range	0...+200°C
	Response value	50...999k Ω	Alarm output	Output mode	2 Relays
	Relative uncertainty	$\pm 10\%$, $\pm 10K$		Contact rating	AC 250V/3A DC 30V/3A
	Response time	$\leq 3s$	Environment	Operating temperature	-10...+55°C
	Permissible system leakage capacitance C_e	$\leq 5\mu F$		Transport temperature	-25...+70°C
	Measuring voltage U_m	$\leq 12V$		Storage temperature	-25...+70°C
	Measuring current I_m	$\leq 5\mu A$		Relative humidity	5%-95%, No condensation
	Impedance Z_i	$\geq 200k \Omega$		Altitude	$\leq 2500m$
	Internal DC resistance R_i	$\geq 240k \Omega$	IP degree		IP40
	Permissible extraneous DC voltage U_{fg}	$\leq DC280V$	Rated impulse voltage / pollution degree		4KV/III
Load	Measuring Value	2.1...60A	EMC/EMR		IEC 61326-2-4

current monitoring	Alarm Value	5...60A	Communication protocol	CAN, customize
	Measuring accuracy	±5%		RS485, Modbus-RTU
Locating ^{note}	Measuring voltage	±12V	Measuring current	≤50μA

Note: AIM-M300 insulation monitoring device doesn't support locating function. When need fault locating function, please select AIM-M300/SG.

4.3 Technical parameters of AIL150-4/AIL150-8 /AIL160-4test signal generator

Refer to Table 4.

Table 4 Technical Parameters of AIL150-4/AIL150-8/AIL160-6

Item		Technical parameters
		AIL150-4/AIL150-8/AIL160-6
Auxiliary power supply	Voltage	DC 18...36V
	Maximum power consumption	≤2VA
Monitored system	Rated voltage	0...242 VAC
	Rated frequency	45... 60Hz
Fault locating	Maximum circuit	4, 8, 6 Loops
	Response time	≤5s
Communication	Mode	CAN communication
	Protocol	Self-defined protocol

4.4 Technical parameters of AID150 centralized alarm and display device

Refer to Table 5.

Table 5 Technical Parameters of AID150 Centralized Alarm and Display Device

Parameters		Type	AID150
AUX POWER	Voltage		DC 24V
	Power consumption		≤0.6W
Insulation Resistance Display Range			0...999k Ω
Insulation alarm range			50...999k Ω
Transformer Output Current Display			Percentage
Current alarm range			14A、18A、22A、28A、35A、45A
Temperature alarm range			0...+200°C
Alarm mode			Audiable and visible alarm

Alarm type	Insulation fault, overload, and over temperature
Communication mode	RS485, MODBUS-RTU
Display mode	LCD display, 128*64 dot array

4.5 Technical parameters of HDR-60-24 power supply device

Refer to Table 6.

Table 6 Technical Parameters of HDR-60-24 Power Supply Device

Type	Input	Output	Installation
HDR-60-24	100-240VAC 1.8A	24VDC 2.5A	35mm DIN-rail

4.6 Technical parameters of AKH-0.66P26 current transformer

Refer to Table 7.

Table 7 Technical Parameters of AKH-0.66P26 Current Transformer

Input current	0.05A~60A	Frequency range	0.02-10 kHz
Output current	0.025~25 mA	Loading resistance	<200 Ω
Temperature coefficient	100 ppm/°C	Transient current (1s)	200A
Phase displacement	10'	Installation	Fixed with 4×10 screws
Operating temperature	-35~+70°C	Secondary wiring	Single core >0.75mm ² , Maximum length of 1 meter
Storage temperature	-40~+75°C		Single core twisted pair, 0.75mm ² , Maximum length of 10 meters
Secondary resistance range	95~120 Ω	Isolation pressure	5000Vac
Accuracy	0.5%	Linearity	0.5%

5 Installation and wiring

5.1 Shape and cut-out

5.1.1 Dimensions of AITR series medical isolation transformer (unit: mm)

Dimensions of AITR series medical isolation transformers are shown as below and in Table 9 (unit: mm)

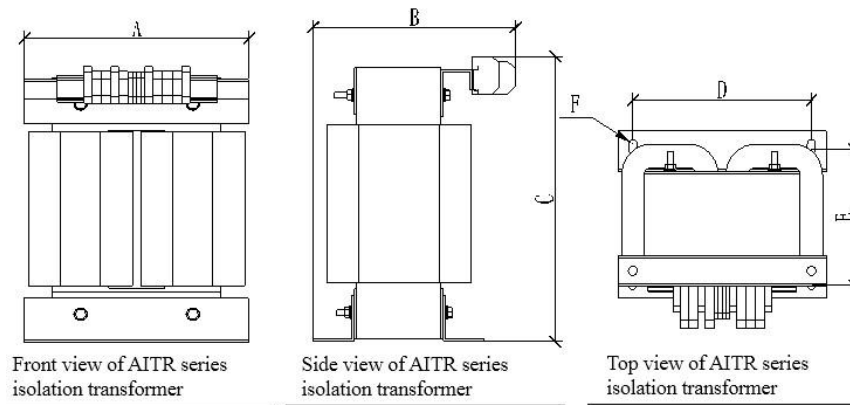

Dimensions of AITR series medical isolation transformer

Table 9 External Dimensions of AITR Series Medical Isolation Transformer

Type	Capacity (VA)	A (mm)	B (mm)	C (mm)	D (mm)	E (mm)	F (mm)	Total weight
AITR10000S	10000	280	236	421	240	190	11*18	86±5
AITR8000S	8000	280	236	421	240	190	11*18	79±5
AITR6300S	6300	280	221	421	240	175	11*18	69±5
AITR5000S	5000	280	211	421	240	175	11*18	62±5
AITR3150S	3150	280	211	421	240	175	11*18	49±5

5.1.2 Dimensions of AIM-M300 series medical intelligent insulation monitoring device (unit: mm)

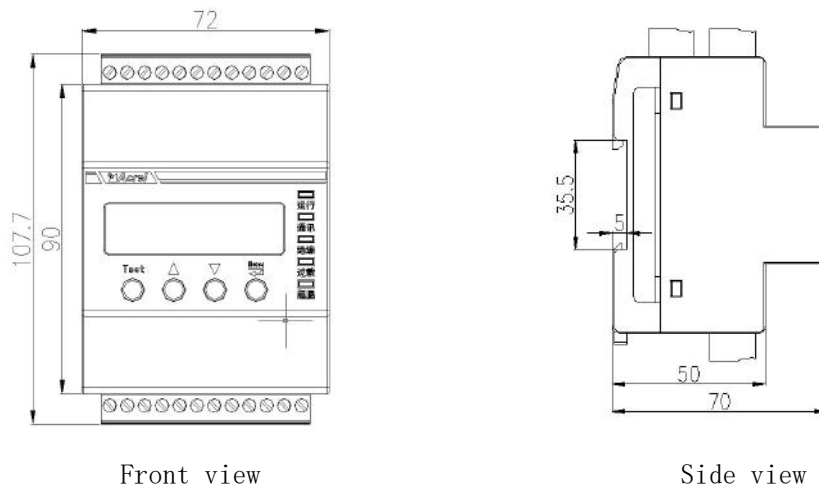

5.1.3 Dimensions of AIL150-4/AIL150-8 /AIL160-6 insulation fault locator (unit: mm)

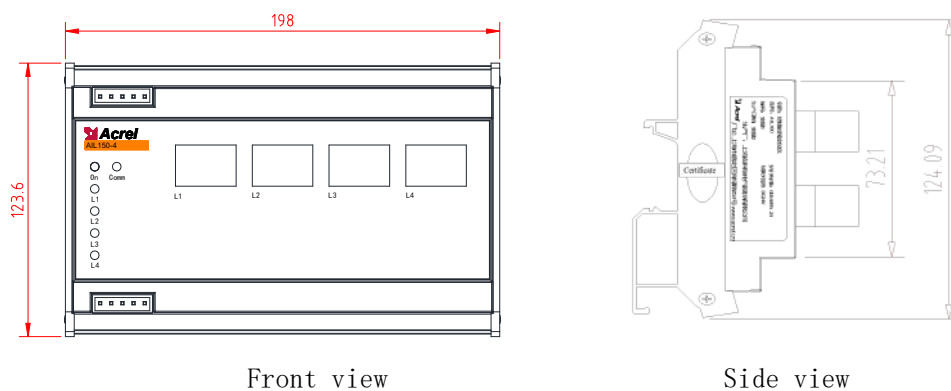

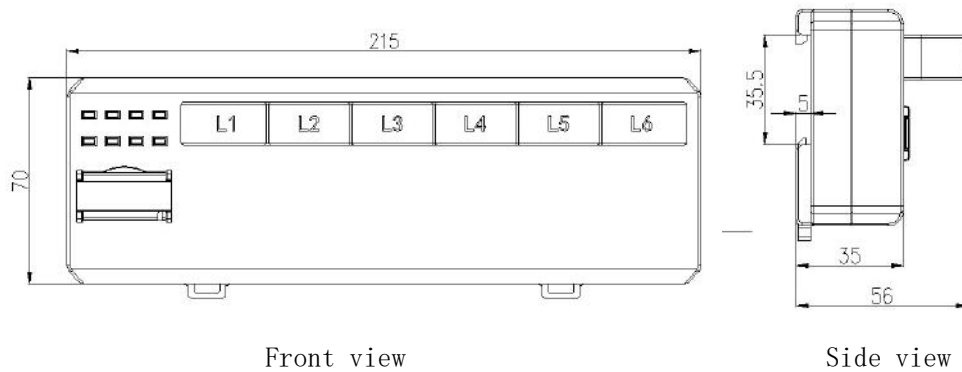

Front view

Side view

Note: AIL150-4 and AIL150-8 these two types take the same product shell, so their external dimensions are exactly the same.

5.1.4 Dimensions of AID150 centralized alarm and display device (unit: mm)

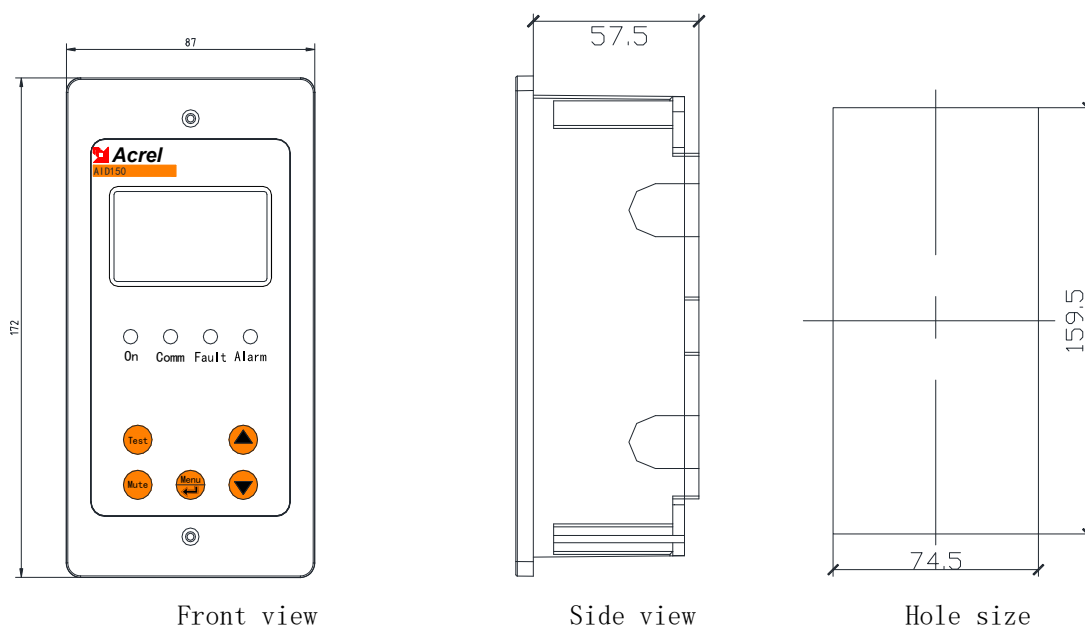

Front view

Side view

Hole size

5.1.5 Dimensions of HDR-60-24 power module (unit: mm)

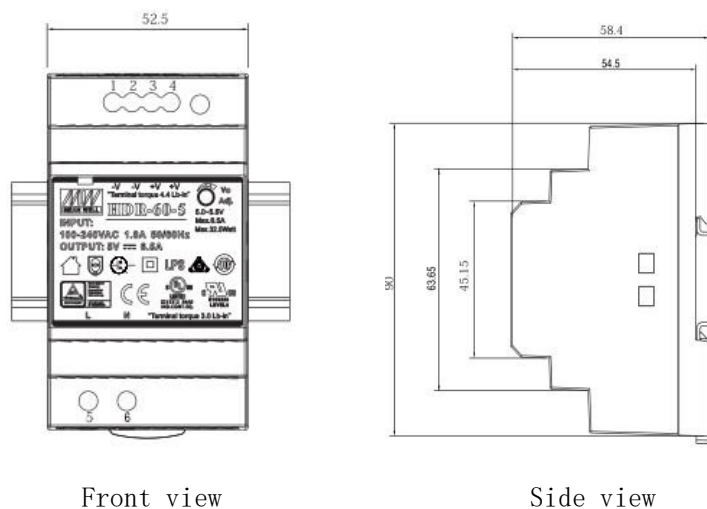

Front view

Side view

5.1.6 Dimensions of AKH-0.66P26 current transformer (unit: mm)

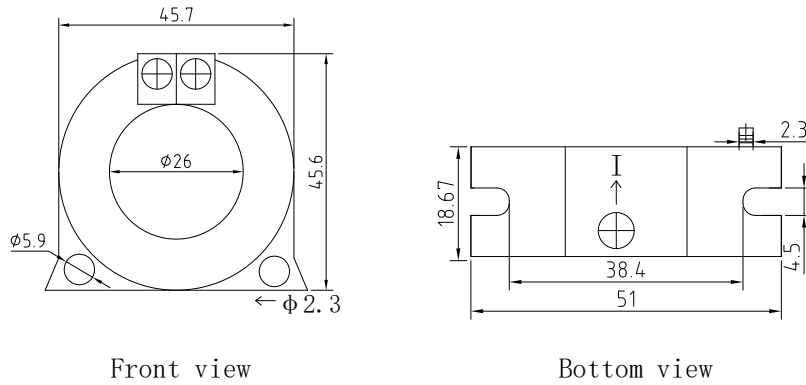

5.2 Installation

Medical IT system insulation monitoring and fault locating device six pieces of products are preferably installed in the distribution cabinet (isolation power cabinet) except for the AID150 centralized alarm and display device. The isolation transformer is installed in the bottom of the cabinet fixed with matching bolts, and the cooling fan should be installed. The device and the circuit breaker are installed on the upper panel. If the isolation transformer is installed separately, it is not suitable to put it too far away from the AIM-M300 series insulation monitor. If the AID150 centralized alarm and display device is used in the operation room, it can be embedded in the wall of the operating room next to the intelligence panel, so that the medical staff can view conveniently. If it is used in ICU/CCU and other intensive care units, it should be installed in the nurses station, so that the duty nurses can view. AID150 external wirings include two 24V power cords and a RS485 communication line of two-core shielded twisted pair, which are all drawn from the isolation power cabinet. Pay attention to reserve pipelines during construction.

5.2.1 Installation of AIM-M300 series medical intelligent insulation monitoring device

AIM-M300 series insulation monitor adopts the installation method of the DIN-rail, and the fixation mode is the clip buckle type, as shown in the following figure:

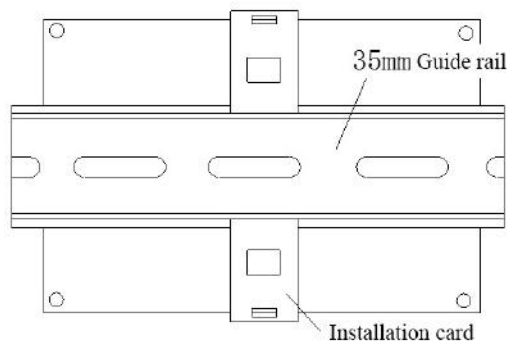

5.2.2 Installation mode of HDR-60-24 power module

The HDR-60-24 power module adopts the installation method of the guide rail, and the fixation mode is the clip buckle type, which can also be installed on the same guide rail as AIM-M300 insulation

monitor.

5.2.3 Installation mode of AIL150-4/AIL150-8 /AIL160-6 insulation fault locator

AIL150-4/AIL150-8/AIL160-6 adopts the installation method of the DIN-rail, and the fixation mode is the clip buckle type, as shown in the following figure:

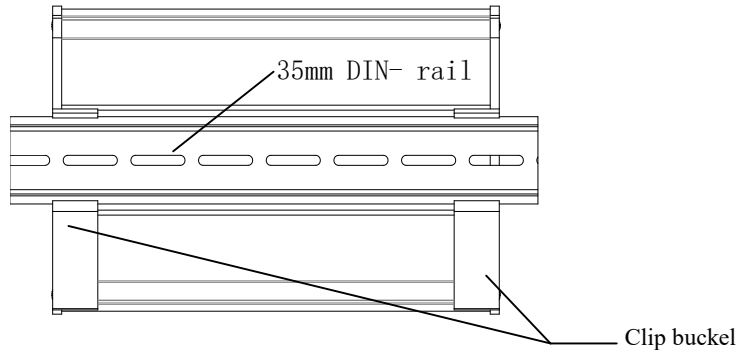

Each branch of IT system must pass through each transformer of the AIL150/AIL160 and then connects to the load, the AIL150/AIL160 should be near the output terminal of each branch during the installation to facilitate the wiring.

5.2.5 Installation mode of AID150 centralized alarm and display device

1) If you choose to embed the wall for installation, the installation diagram is as follows:

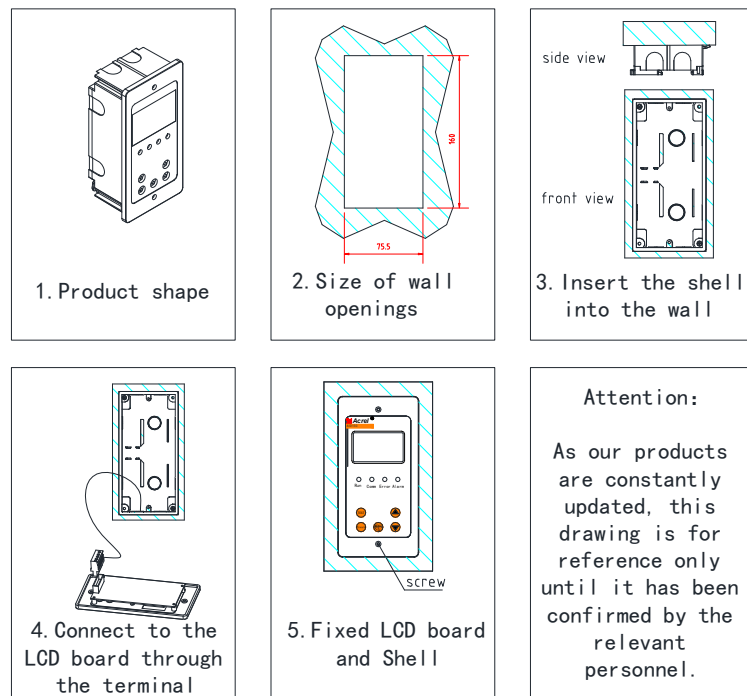

During the decoration, firstly the AID150 shell should be embedded in the wall to be fixed and be close to the knockouts of the pipeline, so that the wires (two power cords + a two-core shielded twisted pair) can be drawn to the front cover, and then fix the cover on the shell with screws.

2) If you choose to install AID150 by opening the cabinet door, the cut-out size is as follows:

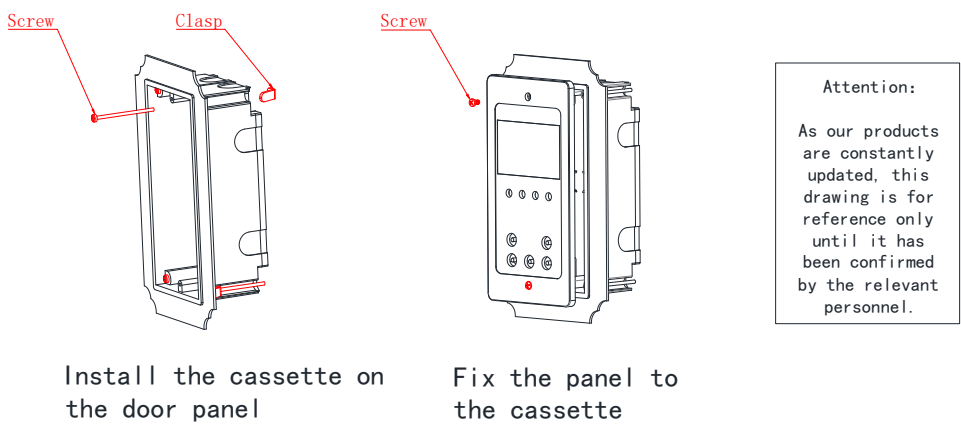
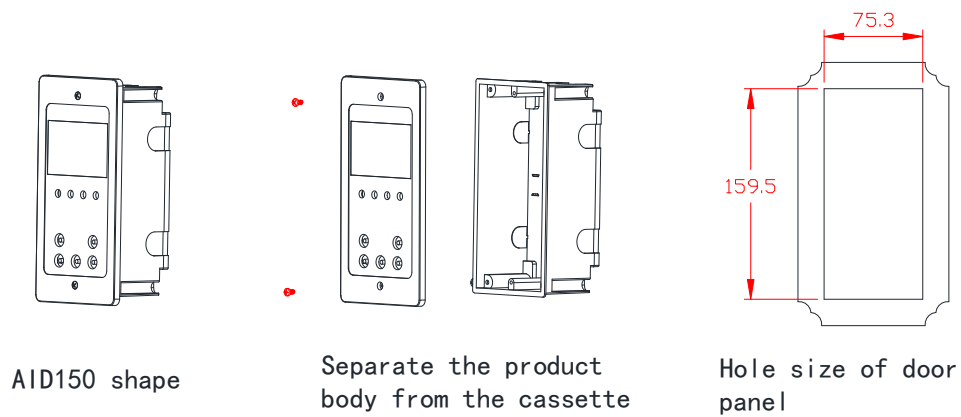

5.3 Wiring method

5.3.1 Wiring mode of AITR series medical isolation transformer

The input terminals at the transformer terminal blocks are labeled with “PM”, in which two terminals 0 and 230 are connected to the input 220V single-phase AC. The output terminals are labeled with “SEC”, in which the output voltage of two terminals 0 and 230 is AC 220V and is connected to external field load. The S terminal is connected to the PE bus bar on the spot (or the equipotential terminal line). Two ST terminals are temperature sensor interfaces, which are respectively connected to the No.11 and 12 terminals of AIM-M300 series insulation monitoring device.

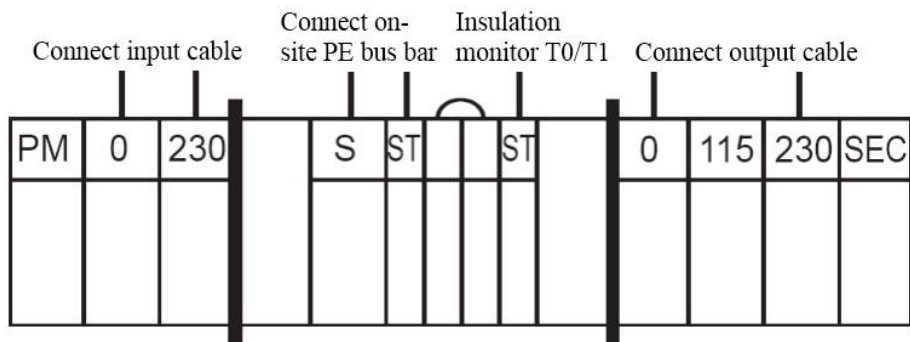
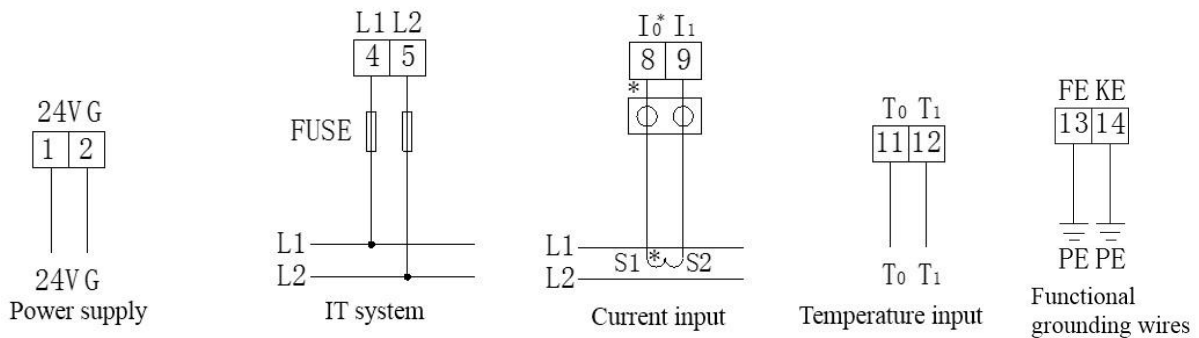

Figure 2 AITR series medical isolation transformer terminal blocks diagram

Note: The wirings of input and output terminals of the isolation transformer should select the copper wires matching the line diameter based on the isolation transformer rated input and output current (refer to tables in section 5.4). S terminal wiring can select $2 \times 2.5\text{mm}^2$ yellow-green wire. The wiring of two ST terminals can select $2 \times 1.5\text{mm}^2$ shielded twisted pairs, and the wiring should not be too long.

5.3.2 Wiring mode of AIM-M300(or AIM-M300/SG)

24V, G for the auxiliary power supply, and L1, L2 are connected to the IT system (which can be connected to the two output terminals of isolation transformer). IO, I1 for the current transformer signal input, and T0, T1 as the temperature sensor signal input. KE, FE are the functional grounding wires, which should be connected to the on-site equipotential terminals by two independent wires.



A and B for RS485 communication terminals, H and L for CAN communication terminal blocks (which are used for the communication connections with AIL150/AIL160 series insulation fault locator and AID150 centralized alarm and display device), J1 for over-temperature alarm output (for control of cooling fan), and J2 for fault alarm relay output.

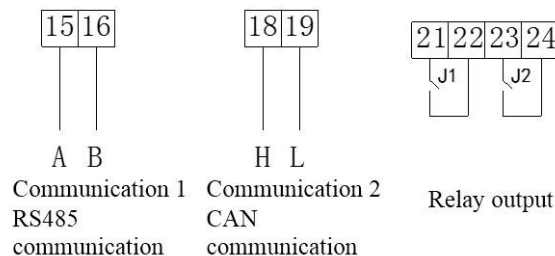

Note:

- 1)  is used for the test terminals of CT secondary side short connection.
- 2) The wirings connecting the No.1 and 2 terminals of the insulation monitoring device to the 24V

power supply can select $2 \times 1.5\text{mm}^2$ copper wires, and the L1 and L2 terminals corresponding to the No. 4 and 5 can select $2 \times 1.5\text{mm}^2$ multistrand copper wires, and the FE and KE terminals corresponding to the No. 13 and 14 can select $2 \times 1.5\text{mm}^2$ yellow-green wires (grounding wires). J1, J2 relay output are the dry nodes, which need additional power supply during the control of external load. For example, J1 controls AC 220V cooling fan, then the AC 220V power supply is needed, and the wiring line type should be determined according to the load current.

3) The transformer signal wires corresponding to the No. 8, 9 terminals, the temperature signal wires corresponding to the No. 11, 12 terminals, the RS485 communication wires corresponding to the No. 15, 16 terminals, as well as the CAN communication wires corresponding to the No. 18, 19 terminals line can select $2 \times 1.5\text{mm}^2$ shielded twisted pairs.

5.3.3 Wiring mode of AIL150-4/AIL150-8 insulation fault locator

Upper row terminals (1-2): 24V, G are auxiliary power supply. Lower-row terminals (21-24, 28): H, L are CAN communication terminals (used for communication terminals connection with medical intelligent insulation monitor, centralized alarm and display device, and test signal generator).

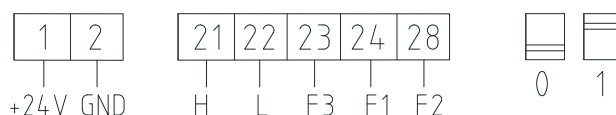

Lower-row terminals (23, 24, 28): F1, F2, F3 are used for the loop expansion function of insulation fault locator. When the number of circuits needed to located is beyond 8 in one set of IT system, you can simultaneously use three (and three at most) AIL150 series insulation fault locators. When expanding the second insulation fault locator, the wiring of terminals F1 and F2 needs to be short circuited; when expanding the third insulation fault locator, the wiring of terminals F1 and F3 should be short circuited. After short circuit connection, the number of branches located by the second fault locator becomes 9-12 (AIL150-4), or 9-16 (AIL150-8); the number of branches located by the third fault locator becomes 17-20 (AIL150-4), or 17-24 (AIL150-8).

5.3.4 Wiring mode of AIL160-6 insulation fault locator

The wiring of AIL160-6 is showed as follow, terminals (1-2): 24V, G are auxiliary power supply. Terminals (21-22): H, L are CAN communication terminals and their expansion terminals.



In order to ensure the normal operation of CAN communication, the CAN interface of each device needs to be connected by a hand in hand approach, at the same time, the head and end of the communication bus wire should be connected with a 120Ω matching resistor. The AIL150/AIL160 series

insulation fault locator can connect the built-in matching resistors to the bus wire in parallel through the dial code switch. When the CAN communications of each device are connected hand in hand, the AIL150/AIL160 can be placed on the head or end of the CAN bus wire, the two dial code switches of AIL150 should be dialed to position 1 (that means the top), for AIL160, NO.1 and 2 code switches dialed to position ON, thus the 120Ω matching resistors can be added to ensure smooth communication. If the AIL150/AIL160 is at the end of the CAN bus wire, the two dial code switches should be dialed to the position 0 (or OFF) to disconnect the matching resistors.

5.3.5 Wiring mode of AID150 centralized alarm and display device

A and B terminals are connected with A and B in the lower terminal of AIM-M300. The terminals of the power supply correspond to the positive pole and ground of the 24V DC power supply respectively. The wiring diagram is shown in the following figure.

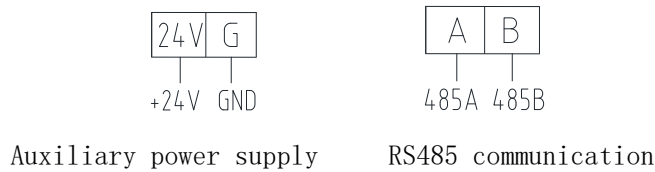

The 24V power supply can be connected by multiple copper wires of 2 x 1.5mm², and the RS485 communication terminal can be connected by shielded twisted pair of 2 x 1.5mm².

5.4.1 Typical wiring diagram

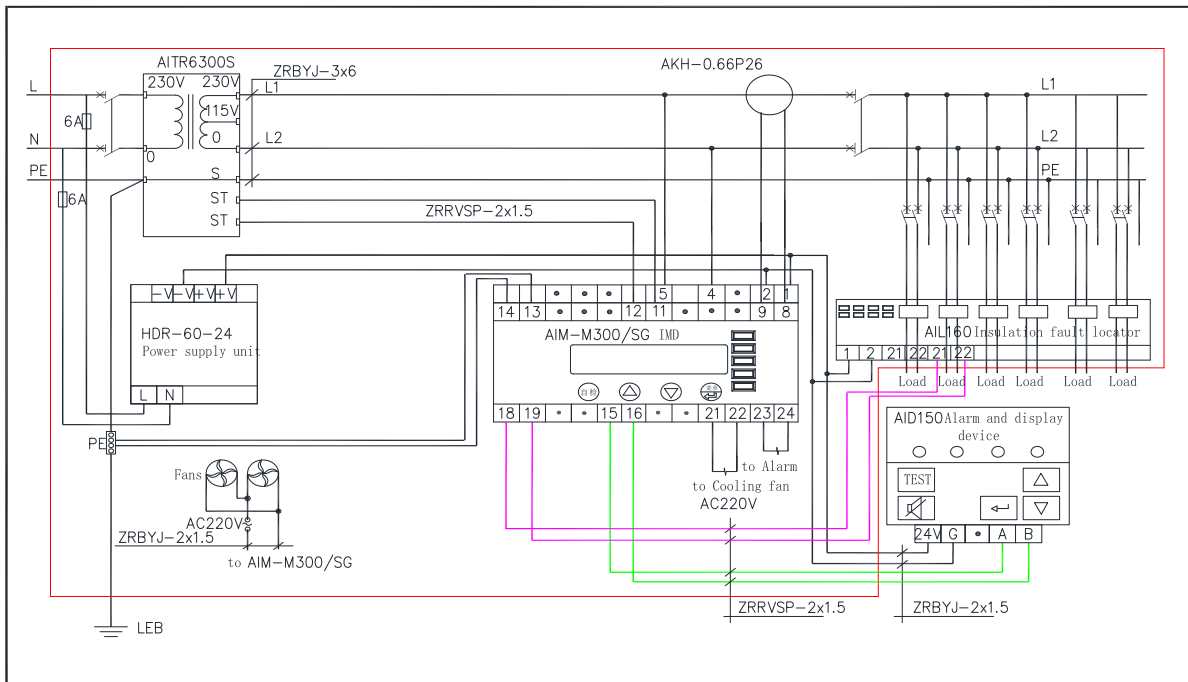

Note:

- 1) The connection line diameter of the input and output of the isolation transformer should match

the rated current of the isolation transformer, or it can be selected according to the following table:

Isolation transformer type	Selected line diameter
AITR3150S	$3 \times 4\text{mm}^2$
AITR5000S/AITR6300S	$3 \times 6\text{mm}^2$
AITR8000S/AITR10000S	$3 \times 10\text{mm}^2$

2) The auxiliary power supply for AIM-M300 series insulation monitoring device (corresponding terminals: No.1, 2), AIL150/AIL160 insulation fault locator (corresponding terminals: No.1, 2), and AID150 centralized alarm and display (corresponding terminals: 24V, G) are all DC 24V, which is supplied by the HDR-60-24 DC power module (24V output terminals: No.3, 4). Considering that the switching power supply may interfere with the IT system, the AC 220V (corresponding terminals: No.1, 2) input by DC power module should be connected to the input terminal of the isolation transformer and be connected with the 6A fuse.

3) The relay output of the AIM-M300 series insulation monitor (No.21 and 22 terminals) is a dry node, which needs an additional fan power supply when used for the fan control. When multiple transformers are centrally installed in one isolation power cabinet, multiple fans should be connected in a parallel mode controlled by multiple insulation monitors, that is, every one insulation monitor can start or stop all fans.

4) AKH-0.66P26 only needs to pass through one of the L1, L2 two wires of the isolation transformer secondary side, but can not pass through the two wires simultaneously. The output is connected with the $2 \times 1.5\text{mm}^2$ wire to the No.8, 9 terminals of AIM-M300(or AIM-M300/SG), which is not allowed for grounding.

5) In order to reliably monitor the grounding insulation of IT system, the No.4, 5 terminals of AIM-M300 series insulation monitor should be reliably connected to IT system (which can be connected in parallel to the output terminal of the isolation transformer) with $2 \times 1.5\text{mm}^2$ multicore copper wires, and the No.13, 14 terminals should be respectively connected to the on-site equipotential terminals (or the grounding terminals in the isolation power cabinet) with two independent 2.5mm^2 yellow-green grounding wires.

6) In order to realize reliable fault location, the two load distribution wires (excluding PE wire) of each branch of the isolation power system should together pass through each transformer of the AIL150/AIL160 series fault locator in a top-down method, and then are connected to the terminal load.

7) The CAN communication line between AIM-M300(or AIM-M300/SG) (terminals 18 and 19), and AIL150/AIL160 (terminals 21 and 22) can be connected by $2 \times 1.5\text{mm}^2$ shielded twisted pair. When

wiring, the method of hand-in-hand (that is, after the communication line of the previous device is connected to the communication terminal of this device, it is led out from the terminal of this device and connected to the communication terminal of the following device). The head and end of the CAN bus One matching resistor shall be connected in parallel between the two communication terminals. The recommended resistance value is 120 Ω . Terminals 13 and 14 of AIM-M300 (or AIM-M300/SG) are RS485 communication terminals, which are used to communicate with AID150.

5.5 Note

(1) Medical IT system insulation monitoring and fault locating six pieces of products should be centrally installed in the isolation power cabinet except for AID150. If the field space is limited, the isolation transformer can be installed separately, but should not be too far away from the insulation monitor and the load.

(2) The installation of wiring should strictly follow the wiring diagrams, which should preferably use the pressure connection with the needle-type fittings, and then insert into the corresponding terminal of the device and tighten the screws to avoid the abnormal work conditions of device caused by loose connection.

(3) The grounding wire of the device and the transformer shall be reliably connected with the equipotential terminals in the field. When applying the isolation power cabinet, it should be connected to the grounding terminals in the isolation power supply cabinet, and then to the equipotential terminals in the field.

(4) The current input of AIM-M300 series medical intelligent insulation monitoring device should use a matching AKH-0.66P26 type current transformer. It is recommended to use pressure connection with U-type indenters during wiring operation, and then connect to the CT terminal. Do not directly use the bare head connection, for the considerations of reliable connection and easy disassembly. Before removing the wiring, the CT primary circuits must be cut off or the secondary circuits must be short connection.

(5) Special reminder:

Any isolation transformer will have an inrush current when it starts, and too large inrush current may cause the circuit breaker at primary side of the transformer difficult to switch or sh. Therefore, for medical IT systems composed of medical isolation transformers and insulation monitoring products, in the selection of inlet circuit breaker of the isolation transformer, it is recommended to choose the circuit breakers only with short circuit protection but without overload protection according to standard requirements. If choosing the circuit breaker with overload protection, the circuit breaker should conform to the C and D tripping curves and the rated current of the circuit breaker should be determined according to the capacity of the isolation transformer as follows: 10kVA-63A,

8kVA-50A, 6.3kVA-40A, 5kVA-40A, 3.15kVA-20A.

If the circuit breaker selection is not in accordance with the above requirements, the company shall not be liable for any medical malpractice caused by the closure difficulty of the circuit breaker or the disconnection of the circuit breaker during operation.

6 Programming and application

6.1 Panel description

6.1.1 AIM-M300(or AIM-M300/SG) panel description

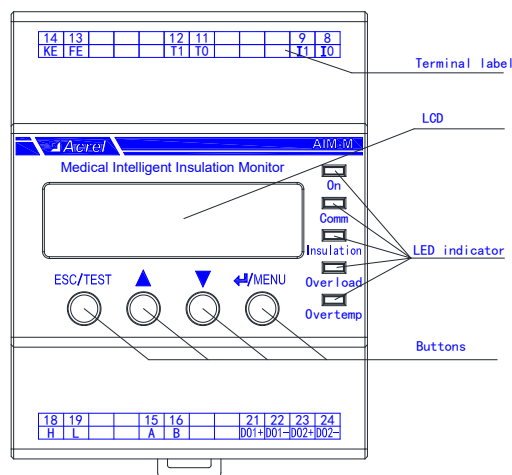

AIM-M300 series medical intelligent insulation monitoring device panel

6.1.2 Dial switch description of AIL160-6 insulation fault locator

Open the cover plate on the panel, there are ten dial switches in it. Functions of each dial switch are showed in the following table.

DIP Switch									
1	2	3	4	5	6	7	8	9	10
Matching Resistor		Reserved					Loop		
1	2	Matching Resistor	8	9	10	Loop			
0	0	Disconnect	0	0	0	L1-L6			
0	1		0	0	1	L7-L12			
1	0	Connect			
1	1		1	1	1	L43-L48			
Attention: 1: on 0: off									

Dial switch No.1,2 for 120Ω matching resistance for CAN bus, all dial to position “0” mean switch off the resistance, dial to position “1” mean switch on.

Dial switch No.3~7 are reserved.

Dial switch No.8,9,10 are used to set the number of channels, dial to “000”, mean channel L1-L6, dial to “001”, mean channel L7-L12, and so on. Totally, 8 AIL160-6 can be used in one IT system,

and locate 48 channels in all.

6.2 LED indicator instructions

6.2.1 LED indicator instructions of AIM-M300 series medical intelligent insulation monitoring device

Indicator	Instructions
On	When the device operation is normal, the indicator light flashes, with the flashing frequency of about one time per second.
Comm	Indicate the status of device communication, when there is data communication, the indicator light flashes.
Insulation	When the insulation resistance exceeds the alarm value, or when the LL/FK is disconnected, the indicator light flashes to alarm.
Overload	When load current exceeds the total load current of transformer, the indicator light flashes to alarm.
Overtemp	When testing transformer temperature exceeds the alarm value, or when the temperature sensor wiring is disconnected, the indicator light flashes to alarm.

6.2.2 LED indicator instructions of AIL150-4/AIL150-8/AIL160-6 insulation fault locator

Indicator status	Instructions
On	When the device operation is normal, the indicator light flashes, with the flashing frequency of about one time per second.
Comm	Indicate the status of device communication, when there is data communication, the indicator light flashes.
L1...L8	Indicate the circuits of the insulation fault

6.2.3 LED indicator instructions of AID150 centralized alarm and display device

Indicator status	Instructions
On	When the device is in normal operation, the indicator flashes, and the flickering frequency is about once a second.
Comm	Indicate the status of device communication, when there is data

	communication, the indicator light flashes.
Fault	When AIM series monitor detect disconnection failure, indicator flashes alarm
Alarm	When AIM-M series monitor exceed threshold alarm, indicator flashing alarm

6.3 Button function descriptions

6.3.1 Button function descriptions of AIM-M300 series medical intelligent insulation monitoring device

AIM-M300 has four buttons in total, namely the “Set and Enter” shared button, “▲” Up button, “▼” Down button, and “Test” button.

Buttons	Button function
Enter/Menu	In non-programming mode, press this button to enter the programming mode; In programming mode, used as the Enter button.
▲ ▼	In non-programming mode, used to view the fault records, the version signal. In programming mode, used to increase or decrease the values and digits, or to change the protection action status
Return/Test	In operation state, used to start the test function of device. In other state, used as return function.

6.3.2 Button function descriptions of AID150 centralized alarm and display device

The centralized alarm and display device has five buttons in total, namely the “Eliminate sound button”, “Menu and Enter” shared button, “▲” Up button, “▼” Down button, and “Self-test” button.

Key	Functions
Mute	When there is alarm, press this button to mute the alarm sound.
▲ ▼	In programming mode, used to increase or decrease the single-digit.
Test	In non-programming mode, used to start the self-test function of device. In other state, used as return function.

Menu/Enter	In non-programming mode, press this button to enter the programming mode;
------------	---

6.4 Button operation descriptions

6.4.1 Button operation of AIM-M300 series insulation monitoring device in RUN mode

(1) Enter RUN the operation mode.

The mode of the default entry is RUN mode, after the LCD displays the software version number, without any operation, the system goes into RUN mode and starts operation. The main interface shows the insulation resistance value, temperature value, current value, load rate and system time.

(2) View the alarm records.

In the main interface, press "Down button" to enter the "Fault records query" interface, and press "enter" button to confirm, turn the pages by pressing "Down button" or "Up button" to query each fault record in sequence. The first record is the most recent record, and the tenth is the oldest record.

(3) View software version information.

In the main interface, view the version information of the software by pressing the "Down button" twice consecutively.

(4) Register address (CAN communication address) to AID200. When AIM-M300 series IMD and AID200 are used together, if AIM-M300(or AIM-M300/SG) doesn't successfully register address to AID200, the manual registration is required. In the main interface, press the "Down button" three times consecutively, entering into the AID200 address registration interface, and press Enter button to achieve address registration. After the registration, it will automatically return to the main interface. If the registration is successful, the CAN communication indicator light starts flashing, indicating that communication is normal.

(5) Device self-test.

In the main interface, press the "TEST" button, then the monitor will start the Self-test program, simulating the overload fault, insulation fault and over-temperature fault to test whether the detection function of the device is normal.

6.4.2 Button operation of AIM-M300 series medical insulation monitor in programming mode

(1) Enter the programming mode

In the main interface, press the "Menu" button to enter the password input page of the programming mode. Input the correct password by pressing "Up " or "Down " button, and press "Enter" button to enter the programming mode.

(2) Exit programming mode

In the programming mode, press the "Return" key to enter the save confirmation menu, select [Y] or [N] by the "UP" or "DOWN" key, and then press the "ENTER" key to exit the programming mode. If [Y] is selected before exit, the parameter settings will be saved; if [N] is selected, the parameters will not be saved.

(3) System password setting

In programming mode, select [Other Settings] by "Up " or "Down " button, and press "Enter" button

to enter other settings item, then change the password number by "Up" or "Down" button, then press "Enter" button to confirm it. Press "Return" button to save and exit programming mode. Examples of operations are as follows:

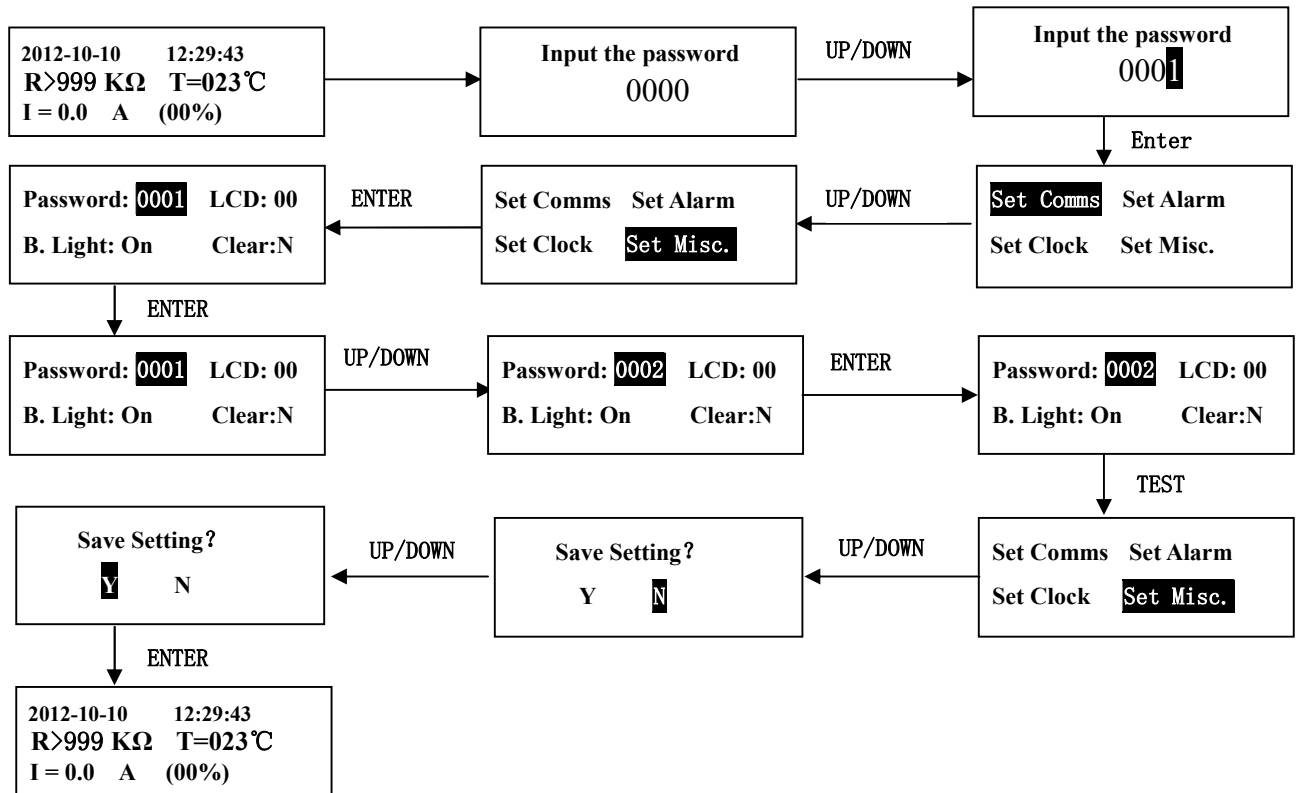

(4) Alarm parameter setting

Alarm parameters are used to set the parameters of system insulation alarm, current overload alarm and transformer temperature alarm, which are similar to the steps of "system password setting". The following only provides examples for setting insulation alarm value, current overload alarm value and temperature alarm value. The insulation alarm value is set to 50kΩ, and the current alarm value is set to 14A and the temperature alarm value is set to 70°C. The procedure is as follows:

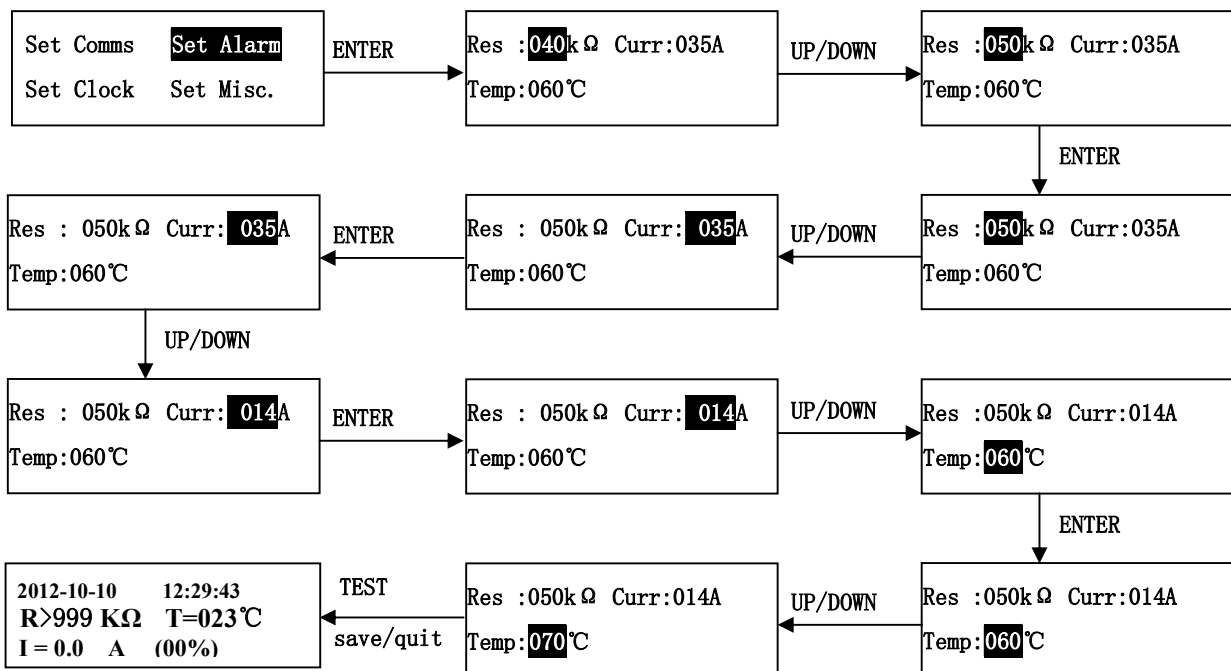

(5) Communication settings

Communication settings include RS485 communication settings and CAN communication settings. The RS485 Communication settings include settings of the communication address and communication baud rate, and CAN communication settings mean to set the communication address, which can also set whether the device is supporting the use of fault locator. The RS485 communication address is set to 005, and the primary baud is set to 9600bps. The CAN communication address is set to 003, with a fault locator. Examples of programming are as follows:

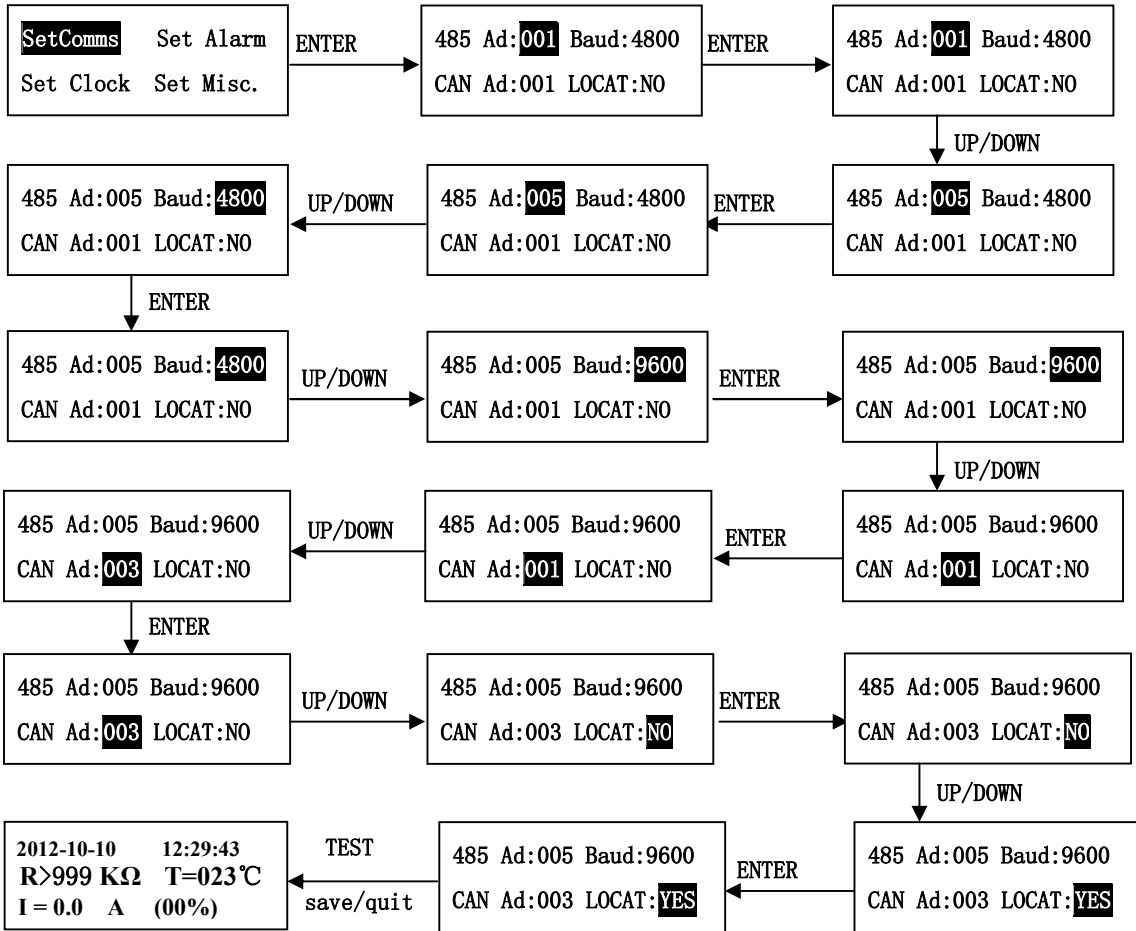

(6) Other parameter settings.

Other parameters settings include contrast settings, backlight time settings, and clearing fault records, which are similar to the setting methods of system password settings. Here is no more descriptions.

6.4.3 Button operation of centralized alarm and display device

6.4.3.1 AID150

1) Description of the Operating Interface

After the system is powered on, if there is no fault alarm, AID150 shows the normal operation interface as shown in the following figure. The black boxes in the figure indicate that the corresponding address serial number is connected to the device communication, and the black boxes indicate that there is no device connection, or that the communication is not connected. When the

insulation monitor or residual current monitor detects the fault, AID150 displays the corresponding alarm interface and sends out the corresponding sound and light alarm.

```

-----
System normal
--■□□□□□□□□□□□□□□□□--
2015-07-02 12:30:45
    
```

Normal system

```

System fault (01/02)
Loc. :ICU Bed:04
Fault type:Insu
BRK      OL      OT
    
```

fault indication (AIM-M300)

```

System fault (02/02)
Loc. :OR Room:06
L1:OK    L2:OK
L3:OK    L4:ORC
    
```

fault indication (AIM-R100)

2) Fault record viewing interface operations and descriptions

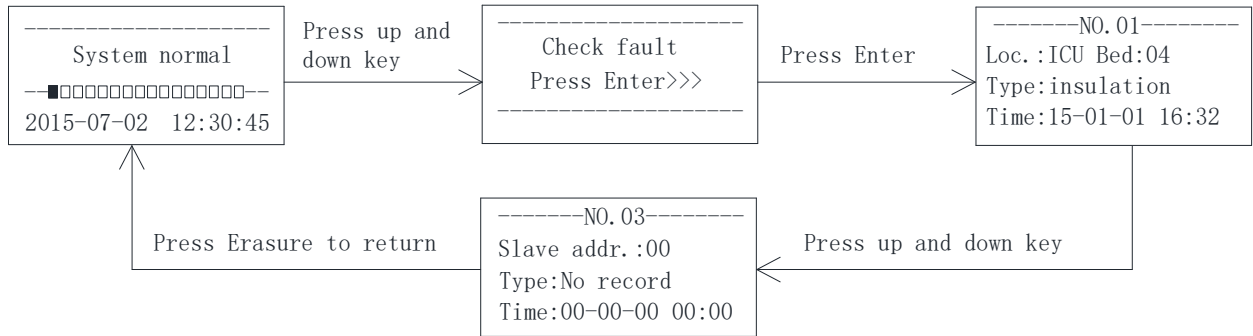

3) Programming Interface Operation and Explanation

The operation method and process are shown in the following flow chart.

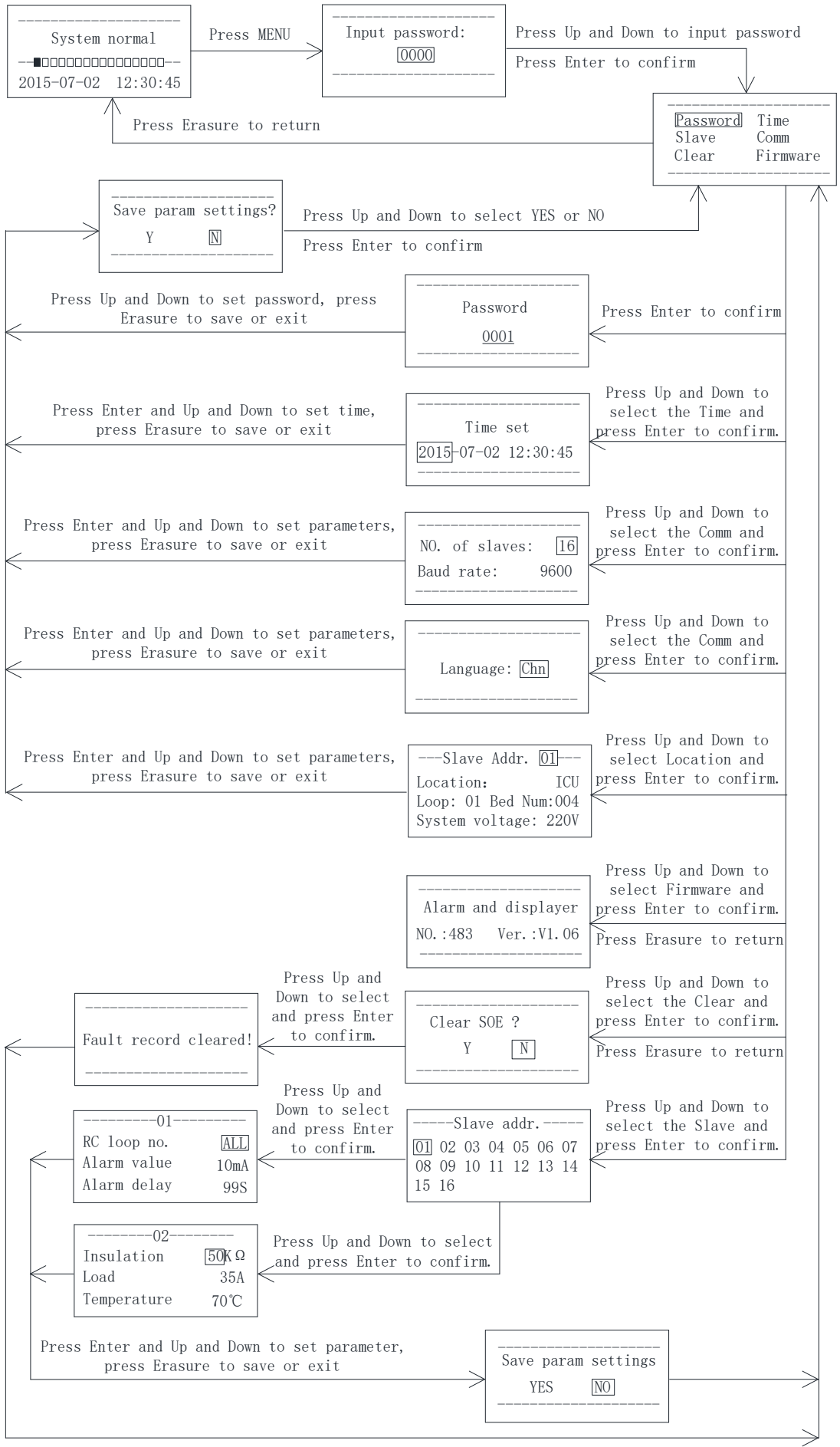

7 Communication protocol

7.1 Modbus-RTU communication protocol

7.1.1 Introduction

In six pieces of products, the communication between the AIM-M300(or AIM-M300/SG) insulation monitor and the upper computer by the Modbus-RTU communication protocol. The Modbus protocol particularly defines the check code, the data sequences and so on, which are the necessary contents of the specific data exchange. The Modbus protocol uses a master-slave responsive connection (half-duplex) on a communication line, which means the signal on a single communication line is transmitted in two opposite directions. Firstly, the signal from the main computer is addressed to a unique terminal device (slave computer), and then the answering signal emitted from the terminal device is transmitted to the host in the opposite direction.

The Modbus protocol only permits communication between hosts (PC, PLC, etc.) and terminal devices, without allowing the data interchange between independent terminal devices. So that terminal devices do not occupy communication lines when they are initialized and are limited to in response to the query signals arriving at the computer.

7.1.2 Introduction to the function code

7.1.2.1 Function code 03H or 04H: Read the registers

This function allows the user to acquire the data collected and recorded by equipment and the system parameters. The number of data requested by hosts has no limit, but cannot exceed the defined address range.

The following example shows how to read a measured insulation resistance value from No.01 slave computer, with the address of the insulation resistance value of 0008H.

The host computer sends		Send message	The slave computer returns		Return message
Address code		01H	Address code		01H
Function code		03H	Function code		03H
Start address	High byte	00H	Bytes		02H
	Low byte	08H	Register data	High byte	00H
Number of registers	High byte	00H		Low byte	50H
	Low byte	01H	CRC check code	High byte	21H

CRC check code	High byte	74H		Low byte	75H
	Low byte	0CH			

7.1.2.2 Function code 10H: Write the registers

The function code 10H allows the user to change the contents of multiple registers, which can write the time and date in this meter. The host can write up to 16 (32 bytes) data at a time.

The following example shows a preset address of 01 with an installation date and time of 12:00, Friday, December 1st, 2009, in which the Monday to Sunday are replaced with number 1 to 7.

The host computer sends		Send message	The slave computer returns		Return message
Address code		01H	Address code		01H
Function code		10H	Function code		10H
Start address	High byte	00H	Start address	High byte	00H
	Low byte	04H		Low byte	04H
Number of registers	High byte	00H	Number of registers	High byte	00H
	Low byte	03H		Low byte	03H
Bytes		06H	CRC check code	High byte	31H
0004H Data to be written	High byte	09H		Low byte	C9H
	Low byte	0CH			
0005H Data to be written	High byte	01H			
	Low byte	05H			
0006H Data to be written	High byte	0CH			
	Low byte	00H			

	byte	
CRC check code	High byte	53H
	Low byte	3FH

7.1.3 Parameter address table in AIM-M300 series medical intelligent insulation monitoring device

No.	Address	Parameter	Read-write property	Value range	Data type
1	0000H	Protecting passwords	R/W	0001-9999 (Default value is 0001)	Word
2	0001H high byte	RS485 Communication address	R/W	1~247 (Default value is 1)	Word
	0001H low byte	RS485 Communication BPS	R/W	1~4 : 4800 、 9600 、 19200bps (Default value is 2)	
3	0002H high byte	CAN address	R/W	1-110 (Default value is 1)	Word
	0002H low byte	There is fault location device or not	R/W	1: yes, 0: no (Default value is 0)	
4	0003H high byte	LCD contrast ratio	R/W	0-63 (Default value is 0)	Word
	0003H low byte	Backlight timeout	R/W	0: Normally open, 1-99 (Unit is Min)	
5	0004H high byte	Year	R/W	1-99	Word
	0004H low byte	Month	R/W	1-12	
6	0005H high byte	Day	R/W	1-31	Word
	0005H low byte	Week	R/W	1-7	

7	0006H high byte	Hour	R/W	0-23	Word
	0006H low byte	Minute	R/W	0-59	
8	0007H high byte	Second	R/W	0-59	Word
	0007H low byte	Reserve	R		
9	0008H	Insulation resistance	R/W	10-999 (Unit is K Ω)	Word
10	0009H	Load current	R/W	0-500 (Unit is 0.1A)	Word
11	000AH	Transformer temperature	R/W	40-140(Unit is $^{\circ}$ C)	Word
12	000BH high byte	Fault circuit		1-8	Word
	000BH low byte	Fault type	R	Bit0:1 Insulation resistance fault Bit1:1 Overload fault Bit2:1 Transformer overheat fault Bit3:1 L1 or L2 disconnection fault Bit4:1 PE or KE disconnection fault Bit5:1 Temperature sensor disconnection fault Bit6:1 Current transformer disconnection fault (preset) Bit7:1 Device fault	
13- 16	000CH-000FH	Preset			
17	0010H	Insulation resistance set value	R	10-999 (Unit is k Ω) (Default value is 50)	Word

18	0011H	Load current set value	R	0-50(Unit is A) (Default value is 35)	Word	
19	0012H	Transformer temperature set value	R	0-200(Unit is ℃) (Default value is 70)	Word	
20-23	0013H-0016H	Preset				
24	0017H high byte	Preset	R		Word	
	0017H low byte	Event control parameters		The storage event record number of next event		
25	0018H high byte	Event record 1	Reserve	R		Word
	0018H low byte		STA1	R	Event 1 content	
26	0019H high byte		Year1	R	Event 1 time -year	Word
	0019 low byte		Moth1	R	Event 1 time -month	
27	001AH high byte		Day1	R	Event 1 time -day	Word
	001AH low byte		Hour1	R	Event 1 time -hour	
28	001BH high byte		Minute 1	R	Event 1 time -minute	Word
	001BH low byte		Second 1	R	Event 1 time -second	
29-64	001CH-003FH	The rules and formats of the remaining 9 event records in this part of space are the same with event 1.				

7.2 CAN communication description

7.2.1 Introduction

Among the six pieces of products, the AIM-M300 series insulation monitor, AIL150/AIL160 series fault locator form a can communication subsystem. Their address is the same address, and they are distinguished by identification. The communication rate is 400kbps.

7.2.2 Agreement

Frame start	Arbitration segment	Control segment	Data segment	CRC segment	ACK segment	Frame end
-------------	---------------------	-----------------	--------------	-------------	-------------	-----------

When the data frame reaches the terminal device, it enters the addressable device through a simple “port”. The device removes the envelope “envelope” (data header) of the data frame and reads the data. If there is no data, the task requested by the data is executed. Then, if the returned data is available, the data generated by itself is packed in the “envelope”, and the data frames are returned to the sender.

7.2.2.1 Data frame format

7.2.2.2 Frame start

Represent a segment that a frame starts, with dominant of a bit.

The bus wire has two kinds of electrical levels which are “dominant” and “recessive”. When executing the line “and” on the bus wire, the logical value of the dominant level is “0”, and the logical value of the recessive level is “1”. “Dominant” has the meaning of “priority”, as long as there is a unit outputting dominant level, the bus wire is the dominant level. “Recessive” has the meaning of “containment”, only when the output of all units is the recessive level, the bus wire is the recessive level.

7.2.2.3 Arbitration segment

The segment representing the data precedence.

The data frames stipulated in the CAN communication protocol have two formats, which are standard format and extended format, and the arbitration segments of the two formats are different. Acrel AIM-M300/SG insulation monitors uses the standard format, of which the arbitration segment has 11 bits. It is sent in turn from ID28 to ID18, and prohibits the high 7 bits are all recessive.

7.2.2.4 Control segment

The control segment consists of 6 bits, representing the number of bytes in the data segment, and the composition of the standard format and the extended format is different.

The Acrel AIM-M300(or AIM-M300/SG) insulation monitor uses the standard format, consisting of a IDE bit, a reserved bit, and 4 bits of data-length-code DLC.

Note that the bytes of data must be 0-8 bytes, but the receiver does not consider the case of 9-15 as an error.

7.2.2.5 Data segment

Data segment can contain data of 0-8 bytes, starting with the MSB (Most significant bit).

7.2.2.6 CRC 段

7.2.2.6 CRC segment

The CRC segment is the frame that examines the frame transmission error, consisting of 15-bit CRC sequences and 1-bit CRC delimiter (the bit used for separation).

CRC sequence is the CRC value generated by the polynomial, and the calculation range of CRC includes frame start, arbitration segment, control segment and data segment. The receiver calculates the CRC with the same algorithm and makes comparisons. If any inconsistencies, it will notify the error.

7.2.2.7 ACK segment

The ACK segment is used to confirm that the reception is normal, consisting of two bits that are an ACK slot (ACK Slot) and an ACK delimiter.

An ACK is sent in the unit (the sending unit does not send an ACK) which can receive the normal message and belongs to one of all receiving units that are neither in the bus shutdown nor in hibernation. A normal message means a message that does not contain a stuff error, a formal error or a CRC error.

7.2.2.8 Frame end

The frame end is a segment representing the end of the frame, consisting of 7 recessive bits.

7.2.3 Communication application

In communication, a data frame can be divided into multiple segments with different functions. Except for the data segment, the meaning of the other segments has been explained in the previous section, so this section will not explain in detail, and only describes the information of data segment.

The data bits of the example given in this section are hexadecimal. Data segment takes the format of the command (function code) + data.

7.2.3.1 Startup command

01 01

Description: When the AIM-M300 series insulation monitoring device monitors the insulation faults in the isolated power system, it will issue a startup command to initiate the AIL150-4/8 fault locator. After receiving this command, the AIL150-4/8 fault locator begins the insulation fault locating.

7.2.3.2 Fault location results return command

04 01

Description: After the AIL150-4 insulation fault locating is completed, the locating results are sent to the AIM-M300 series medical intelligent insulation monitoring device.

Other commands will not be repeated here.

7.3 Device CAN communication connection and address settings

As shown in 7.2.1, each set of AIM-M300/SG, AIL150 serve as a subsystem formally, while in practical application, the CAN communication connection and address settings should be conducted in the following ways.

1) Connect with shielded twisted pair according to the following figure. Note each of the two terminals of the CAN bus wire should be added a matched resistance of 120Ω.

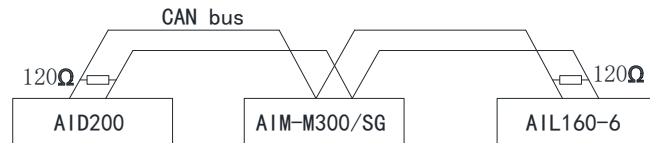

2) When setting CAN address, it is only needed to set the CAN address of AIM-M300 series IMD to any value between 1 to 110 after the 4 meters are on a unified power, then save the value and the CAN address of AIL150 can be simultaneously set the same with address of AIM-M300(or AIM-M300/SG). In the confirmation of saving the AIM-M300(or AIM-M300/SG) CAN address, note whether the communication lights of AIL150 are flashing several times. If flashing, the address settings are normal, otherwise, it is needed to check the communication wiring and confirm that the wiring is intact and then reset.

8 Typical applications

8.1 Applications of insulation monitoring and fault locating six pieces of products in ICU/CCU

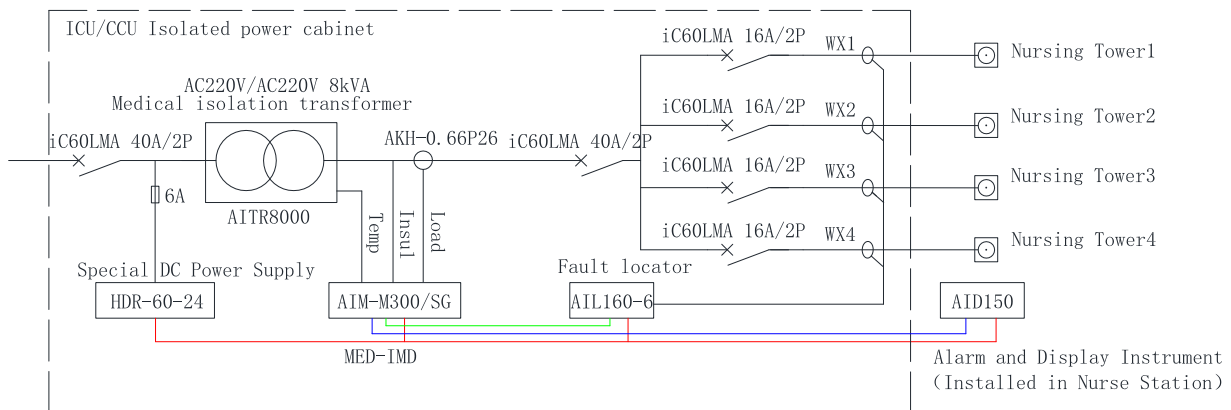

Note: The grounding bar in the isolated power supply cabinet should be connected reliably with the equipotential terminals in the field.

9 Powerup and debugging instructions

9.1 Wiring check

For each set of IT system, the wiring check should be conducted before powerup, mainly checking whether there is wrong, missed or short connection. The examination can be conducted sequentially in the following order according to the wiring diagrams shown in section 5.4 of this manual:

- 1) Check if each six-piece suite forms a separate IT distribution system, and ensure that the current, resistance, and temperature signal wirings of each insulation monitor are connected to the same isolation transformer and IT system composed of it.
- 2) Check whether the L and N input terminals of each set of the HDR-60-24 power supply module are connected to the 0 and 230V terminals of primary side of the isolated transformer. Whether the +V and -V of its 24V output terminal is respectively connected with the No.1(24V) and 2(G) terminals of AIM-M300(or AIM-M300/SG), No. 1(24V) and 2 (G) terminals of AIL150/AIL160, No. 24V and G terminals of AID150, and the positive and negative poles are all correctly connected.
- 3) Check whether the No.8(I0) and 9(I1) terminals of AIM-M300(or AIM-M300/SG) in each system are reliably connected to the terminals of the transformer AKH-0.66P26 socketed to the secondary side of the corresponding isolation transformer, and are not grounded. The transformer only passes one of the two lines of the output terminals of the isolation transformer.
- 4) Check whether the No.11(T0) and 12 (T1) terminals of AIM-M300 series IMD in each system are reliably connected to the two ST terminals of the isolation transformer.
- 5) Check whether the No.4 (L1), 5 (L2) terminals of AIM-M300 series IMD are reliably connected to the two lines of the IT system (that is the secondary side of the isolation transformer).
- 6) Check whether the No.13 (FE), 14 (KE) terminals of AIM-M300 series IMD in each system are respectively connected to the on-site equipotential terminals through wires, in the meanwhile the S terminals of isolation transformer is reliably connected to the equipotential terminals.
- 7) Check whether the No.18 (H), 19 (L) terminals of AIM-M300 series IMD CAN communication in each system are respectively connected to No.21 (h), 22 (L) terminals of AIL150-4 (or-8), and the CAH, CAL terminals of AID200 in the way of hand in hand, which are reliable connections with the positive and negative poles correct.
- 8) If each isolation transformer has a cooling fan, check whether the cooling fan power supply control

is connected to the No.20, 21 terminals of AIM-M300 series IMD in this system.

9) Finally check the two load power lines of each branch in the IT system, and check whether the two lines pass through the transformer on the AIL150/AIL160 panel by a top-down approach.

9.2 Common faults and eliminations

Make sure the wirings are correct and power on the system. Then check whether each device is abnormal, and whether there is a fault alarm in AIM-M300 series device. For common problems, the causes can be determined and the faults can be eliminated according to the phenomenon of each device and the fault types:

Device	Fault phenomenon	Possible causes and troubleshooting
AIM-M300(or AIM-M300/SG) insulation monitoring device	Liquid crystal display: LL disconnection fault, and the insulation indicator is lit.	No.4 and 5 terminals of AIM-M300 series IMD are not reliably connected to the two lines of the output terminal of the isolation transformer. Check the wirings and make sure they are reliably connected.
	Liquid crystal display: FK disconnection fault, and the insulation indicator is lit.	No.13 and 14 terminals of AIM-M300 series IMD are not reliably connected to the equipotential terminals. Check the wirings and make sure they are reliably connected.
	Liquid crystal display: TC disconnection fault, and the overheat indicator is lit.	No.11 and 12 terminals of AIM-M300 series IMD are not reliably connected to the two ST terminals of the isolation transformer. Check the wirings and make sure they are reliably connected.
	Liquid crystal display: insulation fault, and the insulation indicator is lit.	At least one of the two lines in the IT system at the secondary side of the isolation transformer has a grounding fault, after elimination it can be restored to normal.
	The device is not lit.	The 24V power supply of AIM-M300 series IMD is not connected well. Check the wirings of No.1 and 2 terminals and make sure they are reliably connected.

HDR-60-24 power supply module	Powerup indicator is not lit.	Check whether the wirings of 220V power input are normal and whether the voltage between the two terminals is within the allowable input range.
AIL150-4/-8 /AIL160 fault locator	The device is not lit.	The 24V power supply is not connected well. Check the wirings of No.1 and 2 terminals and rewire.
	Unable to locate the insulation fault	1) The communication line with other devices in the system is not connected well. Troubleshoot the communication line and confirm whether the matching resistors are well connected. 2) The CAN address is not set up properly. Disconnect the CAN bus of other connected system devices, and reset CAN address through its corresponding insulation monitoring device. 3) Device problem, which is needed to return to the factory to be solved.
AID150 centralized alarm and display device	The device is not lit.	The 24V power supply is not connected well. Check the wirings of 24V and G terminals and rewire.
	Communication indicator does not flash	1) communication parameters are not set properly, check communication parameters (address, baud rate). 2) The communication line with other devices in the system is not connected well. Troubleshoot the communication line and confirm whether the matching resistors are well connected.

Note: If the above faults occur, interrupt the power to troubleshoot, and adjust the wirings until everything is normal.

9.3 Settings and debugging

1) After the system is powered on, set the AIM-M300(or AIM-M300/SG) load current alarm value according to the capacity of the isolation transformer. The corresponding relations between alarm current and isolation transformer capacity are: 45A---10kVA, 35A---8kVA, 28A---6.3kVA, 14A---3.15kVA. After you set up, follow the process step by step to exit and save the setting parameters. The default alarm current value of the device is 35A, if the matching transformer is 8kVA, then this parameter does not need to be set.

- 2) Open the AIM-M300 series IMD fault locating function. Enter the the communication settings menu and set the LOCAT item to YES, then quit and save to start this function.
- 3) Address settings. To ensure the realization of fault location function, it is necessary to set the can communication address of AIM-M300 series IMD, and set the can communication address of AIL150/AIL160 through this operation. Before setting, make sure that the CAN bus wiring of AIM-M300(or AIM-M300/SG), AIL150/AIL160 and other products in the same it system is correct, and a 120 Ω matching resistance is added at the end (the resistance must be added, otherwise communication may not be possible). You can also connect the AIL150/AIL160 to the head or end of the CAN bus, and turn all its dial switches to the "1" position). Power on the system, enter the communication setting menu of AIM-M300(or AIM-M300/SG), set the can communication address, press enter to confirm, press self check to return and save. If the communication indicators of AIL150/AIL160 flash during the saving process, the can communication address of AIL150/AIL160 is also set successfully. The number of addresses is recommended to start at 1.